

SFP-10"- 33.5"

# Shower Enclosure Installation Guide

Vela Single Fixed Panel

GLASSWAREHOUSE

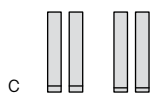
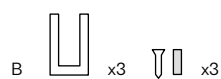
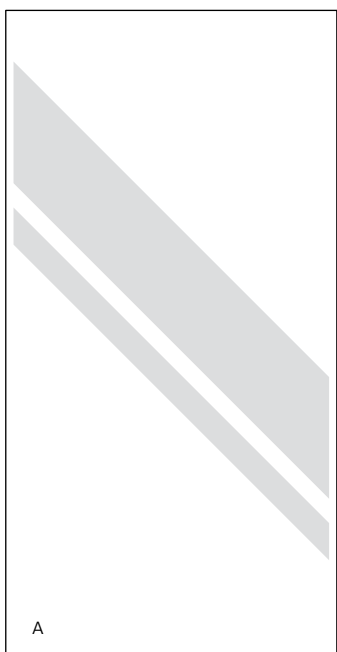

---

**Included in your purchase:**

**A** Fixed panel

**B** Clips, screws and anchors

**C** Rubber block set (various sizes)

# Thank you for your purchase.

If for any reason you are having trouble with installation, or if the size of the product does not fit your designated space, please contact Glass Warehouse directly and do not return this product to place of purchase. We will be able to exchange the panels or parts to suit your opening.

Glass Warehouse takes pride in providing quality products and customer service. We want to ensure your happiness with your purchase for years to come. We have an extensive range of sizes, so no matter what your measurements are, Glass Warehouse can supply the panel to fit!

If you have any questions, please do not hesitate to reach out to us. Thank you again for choosing Glass Warehouse!

Best Regards,

The Team at Glass Warehouse  
Glass Warehouse, LLC  
(760) 536 3640  
[inquiries@glasswarehouse.us](mailto:inquiries@glasswarehouse.us)

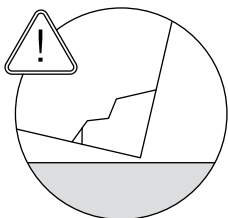

**Caution:** The most fragile parts of tempered glass panels are the corners. Therefore, it is critical you have the rubber blocks in place so the glass never touches the tile surface you are installing onto. Please make sure the glass is always on cardboard packaging or rubber blocks while out of the packaging prior/during install. Rubber block is provided in your hardware pack however you can use wood, cardboard or other rubber products to protect against breakage.



**Attention installer:** A light haze or smudging may be present on the coated glass panels upon delivery. This is easily removed with denatured or isopropyl alcohol and a good quality microfiber cloth, followed by a rinse of water. This can be done before or after installation.

# Installation Guide

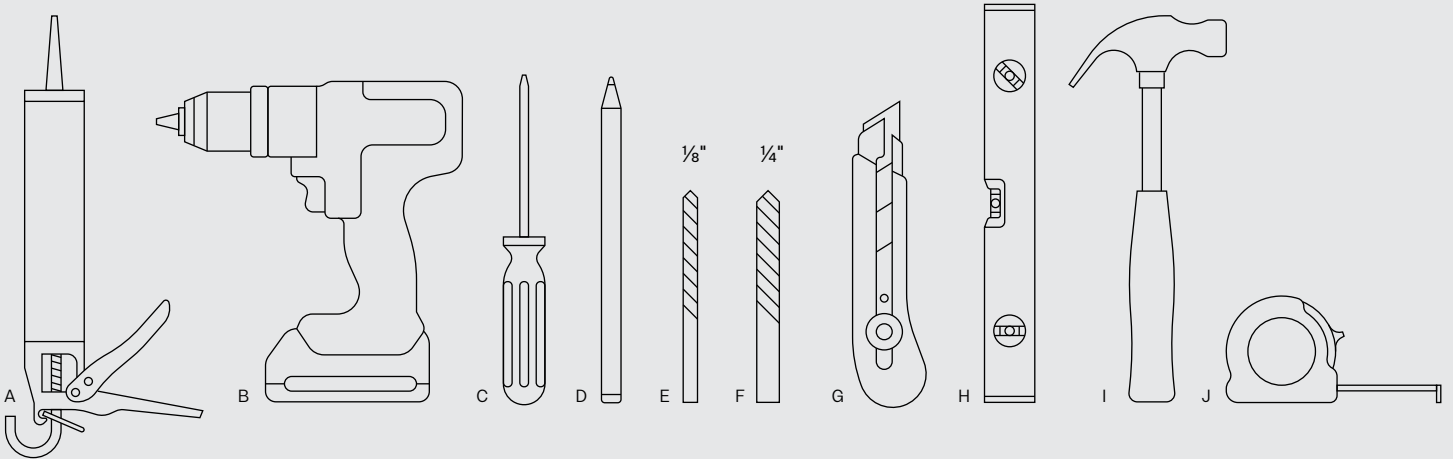

---

## Tools required for install

- |                                    |                              |
|------------------------------------|------------------------------|
| <b>A</b> Silicone and caulkung gun | <b>F</b> 1/4" tile drill bit |
| <b>B</b> Power drill               | <b>G</b> Utility knife       |
| <b>C</b> Phillips head screwdriver | <b>H</b> Level               |
| <b>D</b> Pencil                    | <b>I</b> Hammer              |
| <b>E</b> 1/8" tile drill bit       | <b>J</b> Tape measure        |

**Note:** Silicone is not provided and will need to be purchased separately. We recommend using a clear, mold resistant silicone which can be purchased at your local hardware store.

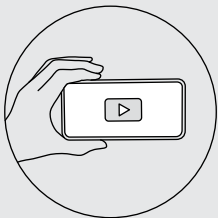

**Watch the video:** View our animation video to assist your installation of the Vela Single Fixed Panel Shower Enclosure:

<https://vimeo.com/352728669>

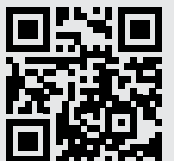

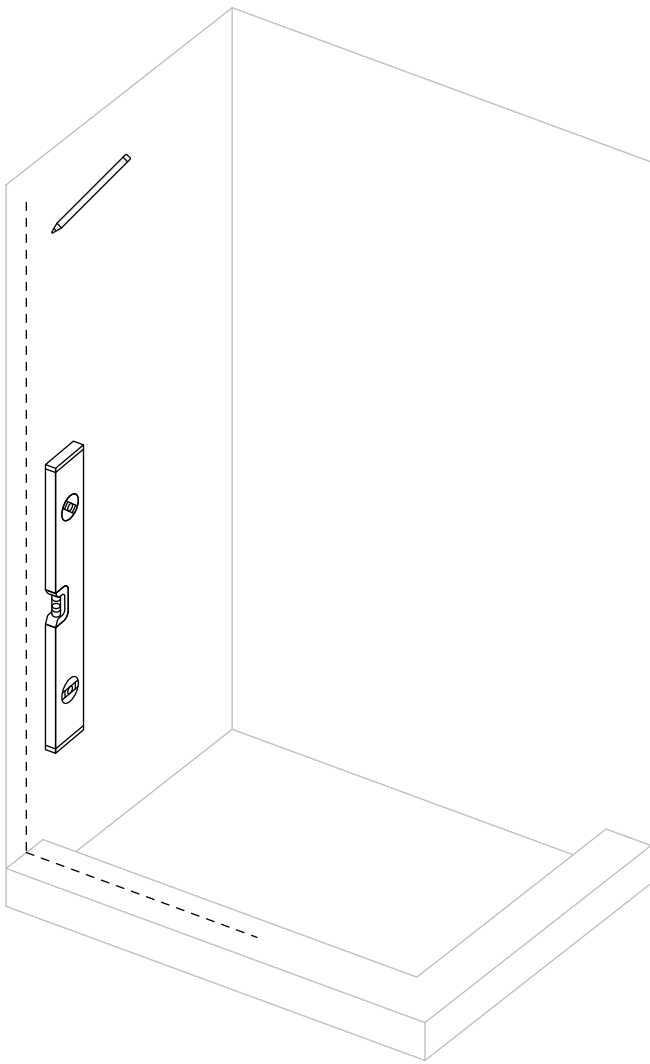

01

**Measure and mark the fixed panel location.**

Use a level and mark a line up the wall and along the floor. This is your center line for the clips.

**Important:** This panel is fully reversible and can be installed on right or left hand wall as needed.



**Tip:** We recommend using a pencil so this can be easily removed.

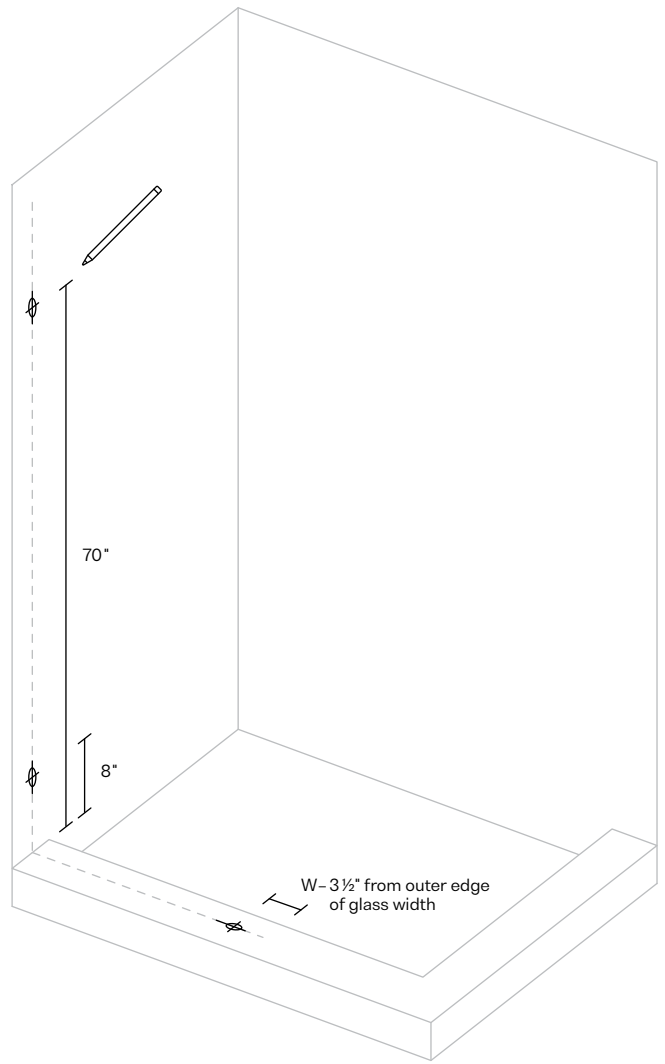

02

**Mark the three clip locations.**

- A** 70" from the floor, up the vertical line.
- B** 8" from the floor, up the vertical line.
- C** Measure width of fixed panel and subtract 3 1/2" - measure this distance out from wall and mark on floor.

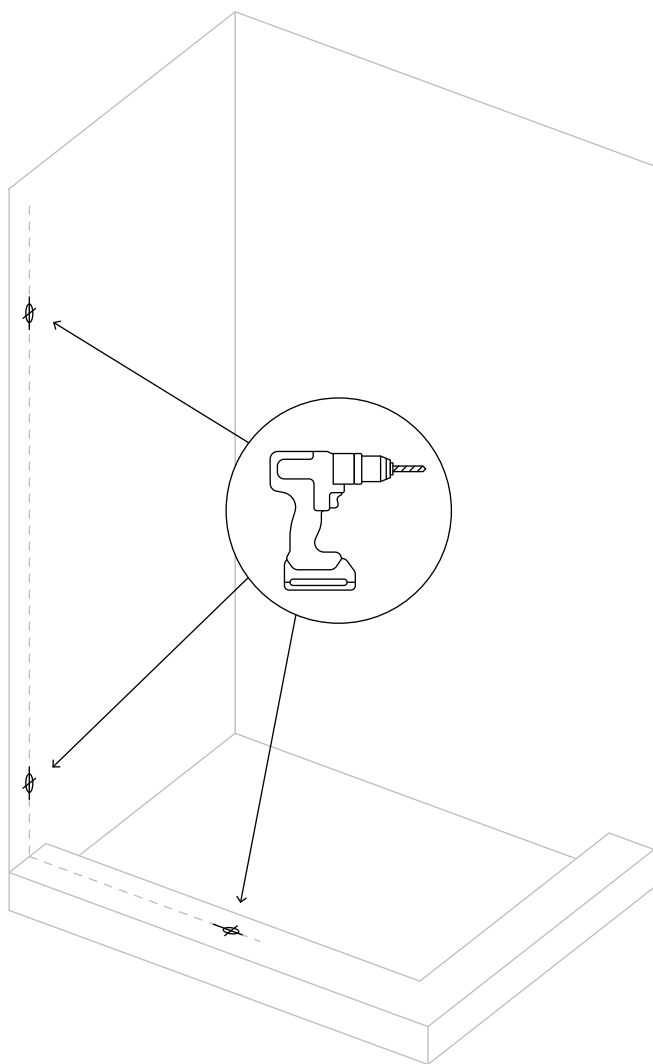

03

**Drill the holes for clips to fix to the wall and floor.**

Using ¼" tile drill bit, drill the three marked holes on the wall and floor. If the shower base is tiled, use the same ¼" tile drill bit to drill the third hole on the floor. If the shower base is fiberglass, use ⅜" drill bit for the floor hole. You will not use the green anchor but rather screw the floor clip directly into base. If you do not want to drill into the fiberglass base, place ⅜" rubber blocks on threshold 3" in from both sides of glass panel and do not use the bottom floor clip. (See Step 05 showing placement of rubber block. The second block would be placed where the clip is shown.)

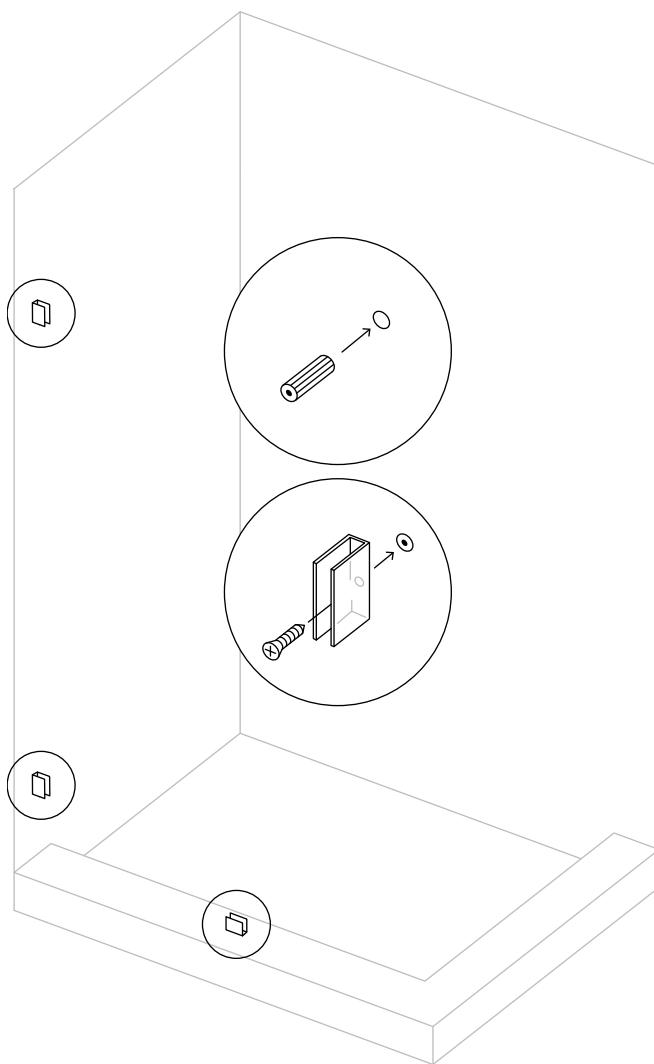

04

**Fix anchors and clips.**

Using a hammer, carefully insert the green wall and floor anchors. Trim any excess from the plug hanging out of hole so your clips can sit flush to wall and floor.

Place clips over holes and drill in screws to secure the clips. Make sure these are securely tightened.

**Important:** There is stamp on the corner of all Glass Warehouse glass panels to certify it is tempered safety glass. We recommend panels are installed with the stamp at the bottom corner closest to the wall where it is less noticeable. On Door Panels, the stamp must be at the bottom for your enclosure to align properly. Note: the stamp is baked on during the tempering process and cannot be removed.



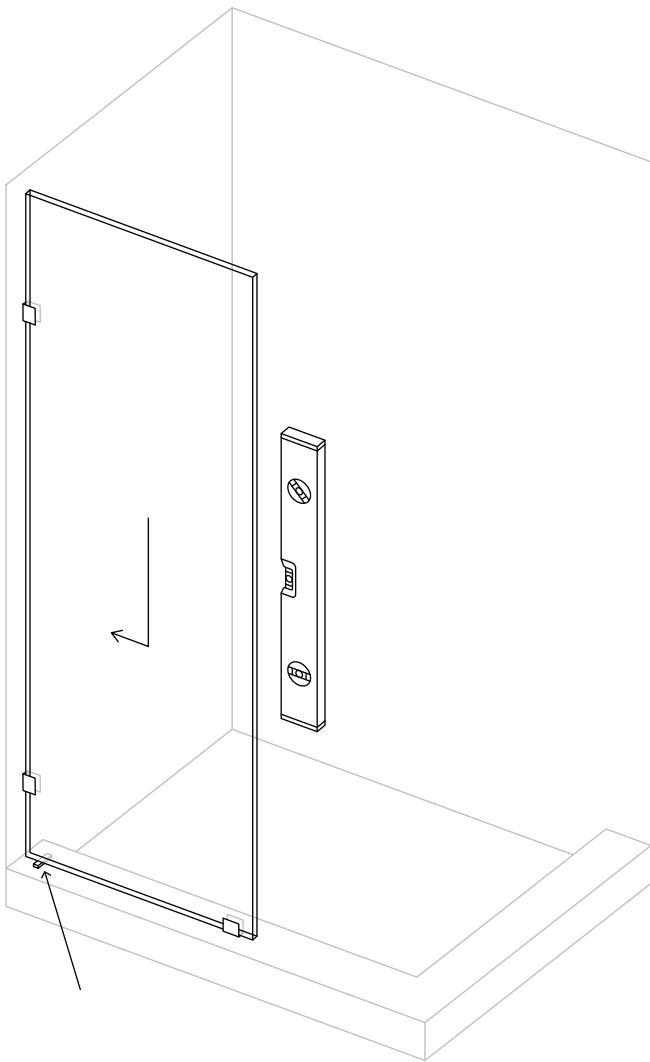

05

### Set the fixed panel in place.

Place the  $\frac{1}{8}$ " rubber block on the floor 3" from the wall. Place a  $\frac{1}{16}$ " rubber block inside the floor clip. Rubber blocks are not required in the wall clips.

Carefully place the fixed panel on the rubber blocks and slot it into the wall clips. Partially tighten screws.

Use a level on the outer-edge to ensure the fixed panel is level and in line.

**Tip:** Use additional rubber blocks on either existing blocks to raise/drop the fixed panel if required.

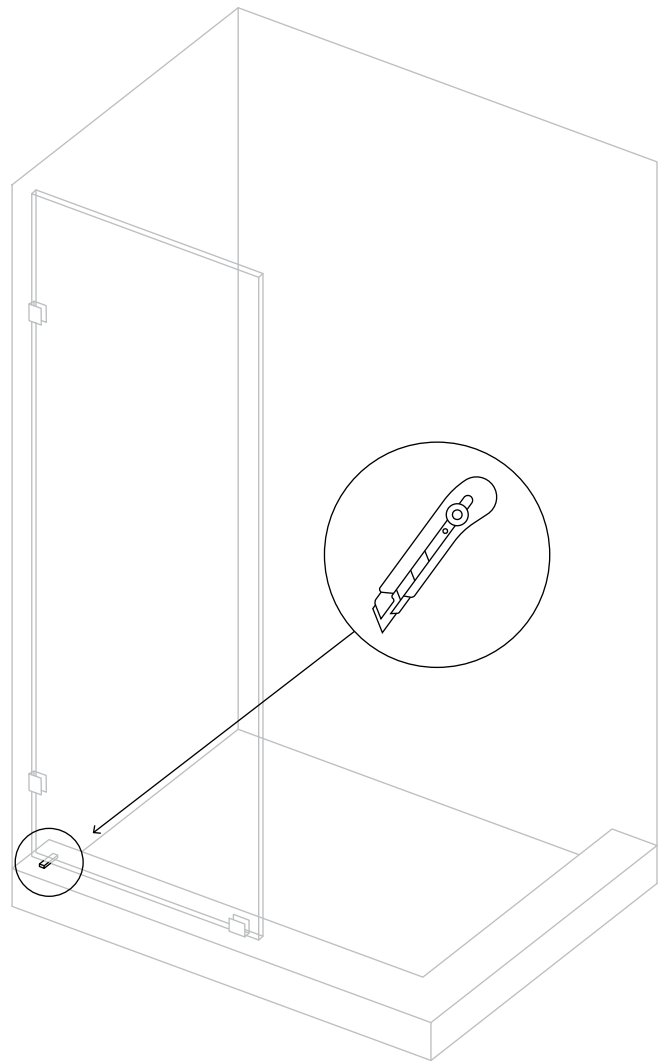

06

### Trim rubber blocks.

Trim the rubber blocks with a utility knife so that they are flush with the glass panels resting on top of them.

If you used 2 rubber blocks on your fiberglass base instead of a clip, trim excess block on both sides of glass panel.

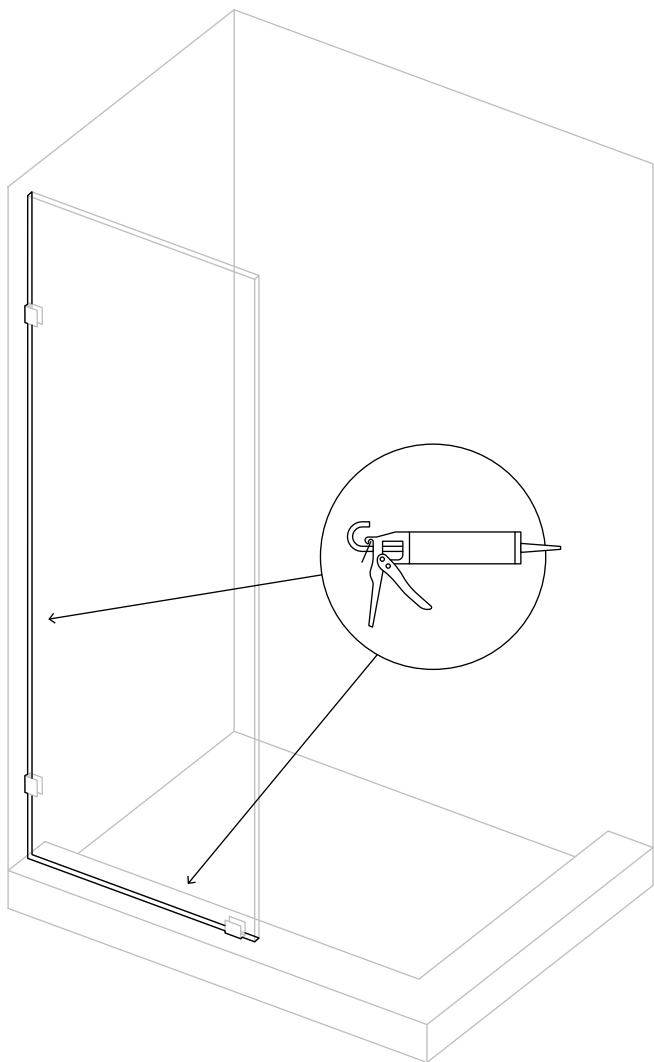

07

---

**Apply silicone to seal fixed panel.**

Apply silicone around the wall and floor surface of the panel. You need to silicone both the inside and outside edges ensuring the gap between glass and tile is completely sealed. Once sealed, spray the silicone with water and use a spatula (available in our Install Kit) to remove any silicone residue.

If you used 2 rubber blocks on your fiberglass base instead of the bottom clip, the silicone will keep your panel in place and secure once it sets.

**Important:** It is critical that the silicone is given 24 hours to set and 48 hours to cure.

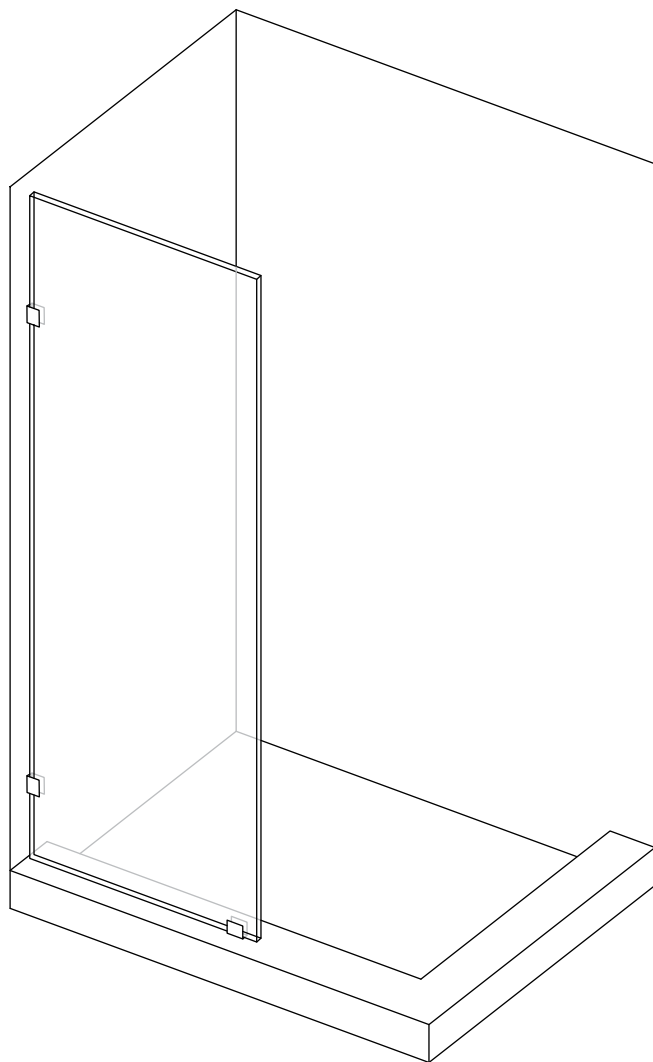

08

---

**Once silicone has cured, you're done.**

Please register your warranty using the instructions on the back cover of this document.



# Care & Maintenance



EnduroShield makes cleaning easier and less frequent; however it is recommended that you continue to clean the surfaces regularly.

## Maintaining the Treated Surface

For best results simply drying the glass with a squeegee or towel after each use will help keep the glass clean and reduce mineral spots forming. The glass needs to be cleaned every few weeks using a damp microfiber cloth and a mild detergent to break down soaps, oils, and conditioners on the glass. General glass cleaners are also suitable, however most of these are finishing agents rather than cleaners, and are an added expense that is not required.

## Hard Water Maintenance

In hard water areas, or areas where water drops dry and leave a noticeable dust mark, a build of minerals may occur on the protective treatment. While these may not be removed as easily with the mild detergent, mild acids will often remove the marks quickly. As needed white vinegar should be used to wipe down the glass. Keep in mind the vinegar may be diluted with water, however dilution reduces the effectiveness.

Spray vinegar onto the glass and allow to soak for several minutes. This should dissolve any mineral deposits that have built up on the glass surface. A damp microfiber cloth should then be used to wipe over the surface. For extreme hard water areas we recommended using undiluted vinegar every week or so as a cleaning option to reduce this build up on the surface, rather than allowing the build up to continue over a long period of time.

**Caution:** Prohibited Products \*Note these may damage the treatment and void any warranty

- Avoid the use of any abrasives or polishes including water spot removers, toothpaste, polishes, rough, or gritty substances
- Avoid the use of acids or alkalis that you would not want in contact with your skin for an extended period of time
- Avoid products such as Comet, Ajax, Jiff or Cerium Oxide which polish back the actual substrate
- Avoid the use of any harsh or chemical cleaners, with correct maintenance these are never required

## Approved Cleaning Products

The below products have been tested for compatibility with EnduroShield, however there are no specific products that must be used. We feel you should not be required to purchase extra products in order to keep your glass clean. With correct maintenance, all you need for clean glass beyond 10 years is a squeegee, a mild liquid dish soap, and white vinegar.

Any product that does not fall into the prohibited categories listed above will be fine, and below is a short list of acceptable products:

- Windex
- SprayWay (or other alcohol based foaming cleaners)
- Scrubbing Bubbles (or other automatic leave-to-dry daily shower cleaners)
- 7th Generation, Dawn (or other mild eco friendly cleaners)
- CLR (Calcium Lime Rust)
- Mr. Clean Magic Eraser (when damp)

It should be noted that with any cleaner used on the EnduroShield surface a thorough rinse with clean water should follow immediately. Although these cleaners can be used, EnduroShield is designed to be an 'easy clean coating' that does not require harsh or toxic cleaning chemicals to maintain the surface effectively.

If for any reason the recommended maintenance has not been followed for some time, just as it took time for the build up to occur, it will take time to remove the debris from the protected glass surface. This can most commonly be achieved using undiluted white vinegar dampened on a Magic Eraser, or CLR on a Magic Eraser. Depending on the severity of the build up this may take multiple attempts, but once the glass is clean again it will perform like new. Should you have any queries regarding the cleaning of your treated surfaces please contact EnduroShield.

tel: 805 617 4609  
email: [salesusa@enduroshield.com](mailto:salesusa@enduroshield.com)  
[www.enduroshield.com](http://www.enduroshield.com)

# Exclusive Limited Warranty Terms & Conditions.

This warranty is effective as of JANUARY 1, 2019 on all Glass Warehouse product purchases

**PLEASE READ GLASS WAREHOUSE WARRANTY TERMS AND CONDITIONS BEFORE INSTALLING YOUR GLASS WAREHOUSE PRODUCT. BY USING THE PRODUCT, YOU ARE CONSENTING TO BE BOUND BY THE FOLLOWING WARRANTY TERMS AND CONDITIONS**

Glass Warehouse offers the following warranty for its products and components thereof. This warranty extends only to the original owner/end-user for household use only and is not transferable to a subsequent owner. Glass Warehouse reserves the right to modify this warranty at any time, it being understood that such modifications will not alter the warranty conditions applicable at the time of sale of the products in question. This warranty extends for a designated period of time, so long as the product remains in use in its original place of installation and that the product must be maintained as described in the owner's manual supplied with the product. This warranty applies only to Glass Warehouse® products purchased from an authorized dealer in the United States or Canada.

**Proof of purchase (original sales receipt) from the original consumer purchase must be provided with all warranty claims.** No responsibility is assumed by Glass Warehouse for any special, incidental or consequential damages. **IN NO EVENT SHALL THE LIABILITY OF GLASS WAREHOUSE EXCEED THE PURCHASE PRICE OF THE UNIT.**

Glass Warehouse products must be installed by a fully insured, licensed professional and according to the Glass Warehouse installation instructions and guidelines. Installation of Glass Warehouse product by anyone other than a fully insured licensed professional shall **VOID THE WARRANTY**. Glass Warehouse recommends that such licensed professionals have experience in the installation of bathroom products -specifically glass shower and glass tub doors. Installation of certain products, including, without limitation, glass products (i.e., shower and tub doors) by an unlicensed or inexperienced installer may result in glass breakage and, consequently, may cause personal injury or even death and Glass Warehouse will not be liable.

## **PARTS ONLY WARRANTY – Limited Warranty 3 years**

This warranty is extensive in that it covers replacement of all defects. Glass Warehouse may, at its option, examine and inspect the alleged defective product and Glass Warehouse may request that parts be returned to Glass Warehouse at Owner's expense for factory assessment and inspection. If Glass Warehouse determines product to be covered by the above Warranty, replacement parts will be shipped via ground shipping. Increased costs for expedited delivery, if requested by the Customer, will be the responsibility of Customer. Parts replaced under the terms of this Warranty will be warranted for the remainder

of the original warranty period. **LABOR CHARGES AND/OR DAMAGE INCURRED DURING INSTALLATION, REPAIR, OR REPLACEMENT, AS WELL AS ANY OTHER KIND OF ANCILLARY COST, LOSS OR DAMAGE ARE EXCLUDED.** Please allow up to 1-3 business days for processing of warranty issued parts. Once warranty replacement parts are shipped, warranty is activated and product cannot be returned for refund thereafter.

## **SHOWER & TUB DOORS, SHOWER ENCLOSURES GLASS**

Glass Warehouse shower doors, tub doors, and shower enclosures are backed by a Limited Lifetime Warranty. Glass Warehouse warrants the glass of shower doors, tub doors and shower enclosures to be free from defects in workmanship and materials under normal residential use for a period commencing from the initial date of purchase by the owner/ end-user, contractor or builder from an authorized Glass Warehouse dealer for the life of the product as long as the original consumer purchaser owns the home in which the product is installed. Warranty for plastic seal strips, sweeps or any other vinyl components shall be limited to one (1) year. Glass Warehouse does not warrant glass for scratches, chips, water spots, breaking or any other damage after installation.

## **SHOWER & TUB DOORS, SHOWER ENCLOSURE HARDWARE**

Glass Warehouse shower door, tub door, and shower enclosure hardware is backed by a Limited Lifetime Warranty. Glass Warehouse warrants shower door, tub door and shower enclosure hardware (i.e. handles, bath knobs, hinges, clips, brackets, shower rods, 90° corner brackets) in chrome, brushed nickel, satin brass and polished brass finishes only to be free from defects in workmanship and materials under normal residential use for a period commencing from the initial date of purchase by the owner/ end-user, contractor or builder from an authorized Glass Warehouse dealer for the life of the product as long as the original consumer purchaser owns the home in which the product is installed. Warranty for any part in oil rubbed bronze or matte black finish shall be limited to one (1) year.

Glass Warehouse hereby disclaims all warranties for products sold as dealer or store displays. Glass Warehouse hereby disclaims all warranties for products used outside of the United States or Canada whether expressed or implied, including but not limited to the implied warranties of merchantability and fitness for a particular purpose.

## **WARRANTY TERMS**

Glass Warehouse will, at its election, repair or replace the product found by Glass Warehouse in its sole judgment, to be defective within the warranty period under normal residential use and maintenance. The replacement of a product is limited to supplying a replacement product or part (same as existing or if not available, comparable product). Glass Warehouse warranty

obligation shall be discharged upon tender of parts, replacement or repair of the product. Purchaser's refusal to accept the tender terminates all warranty obligations and **VOIDS THE WARRANTY**. Cost of freight for returning products to Glass Warehouse for repairs or replacement under this limited warranty are the responsibility of the customer. Cost of freight associated with shipping of replacement product(s) or parts covered by this warranty is the responsibility of the original user. Any product replaced or repaired during the warranty period will be covered only for the remaining period of the original warranty. In no event will Glass Warehouse be liable for costs of repair or replacement of any installation material, including but not limited to tile, marble, etc. **GLASS WAREHOUSE IS NOT RESPONSIBLE FOR INSTALLATION, REMOVAL OR REINSTALLATION COSTS OF ANY PRODUCT REQUIRING WARRANTY SERVICES.**

Any modification or alteration of any Glass Warehouse products will void the warranty. Neither the authorized Glass Warehouse dealer, nor any other person is permitted to make any affirmation, representation, or warranty other than those contained in this warranty. Any affirmation, representation, or warranty other than those contained in this warranty shall not be enforceable against Glass Warehouse or any other person.

Glass Warehouse product installations must be performed by either a Glass Warehouse authorized agent or a licensed, insured and experienced professional contractor - installations performed by any other party shall void the warranty. This warranty shall not apply to breakage or damages caused by normal wear and tear, fault, carelessness, abuse, misuse, misapplication, improper maintenance, alteration or modification of the unit, as well as chemical or natural corrosion, accident, fire, flood or any other casualty. Improper care and cleaning will void the warranty. Use of cleaners containing abrasive cleansers, ammonia, bleach, acids, waxes, alcohol, solvents or other products not recommended for hardware finishes, glass or acrylic as they may damage the metal or glass finish of your shower door or shower enclosure and will void the warranty. For additional product maintenance instructions please refer to the product installation manual. Glass Warehouse is not responsible for any issues arising in connection with errors or omissions in information provided on Glass Warehouse or dealers' websites. This warranty does not extend to any non-Glass Warehouse plumbing or components installed by installers, end users or by any party other than Glass Warehouse.

**THE FOREGOING WARRANTIES ARE IN LIEU OF ALL OTHER WARRANTIES, EXPRESSED OR IMPLIED, INCLUDING BUT NOT LIMITED TO THE IMPLIED WARRANTIES OF MERCHANTABILITY AND FITNESS FOR A PARTICULAR PURPOSE. BATH AUTHORITY LLC ("GLASS WAREHOUSE") AND/OR SELLER DISCLAIMS ALL LIABILITY FOR SPECIAL, INCIDENTAL OR CONSEQUENTIAL DAMAGES. GLASS WAREHOUSE IS NOT LIABLE FOR PERSONAL INJURIES OR DEATH TO ANY PERSON OR FOR ANY DIRECT, SPECIAL,**

**INCIDENTAL OR CONSEQUENTIAL DAMAGE, LOSS OF USE, LOSS OF TIME, LOSS OF PROFITS, INCONVENIENCE, INCIDENTAL EXPENSES, LABOR OR MATERIAL CHARGES, OR ANY OTHER COSTS RESULTING FROM THE USE OF ITS PRODUCTS OR PERTAINING TO THE APPLICATION OF THE PRESENT WARRANTY, OR RESULTING FROM THE REMOVAL OR REPLACEMENT OF ANY PRODUCT OR ELEMENT OR PART COVERED BY THIS WARRANTY.**

#### **COMMERCIAL USE AND OTHER EXCLUSIONS**

This warranty excludes all industrial, commercial and business usage. The warranty period for products installed for commercial applications or used in commercial ventures, including but not limited to motels, hotels, casinos, student housing, condos, apartments, and fitness centers, is a one (1) year limited warranty from the date of purchase for shower doors, bathtub doors, shower enclosures and a three (3) month limited warranty from the date of purchase for mirrors, with all other terms of this warranty applying except the duration of the warranty.

#### **WARRANTY SERVICE**

To activate your limited lifetime warranty, please visit:  
<http://www.glasswarehouse.us/contact/>



Please register your information within 30 days of purchase to complete the activation of your warranty.

**Contact Technical Support:  
Monday – Friday 8am – 5pm – PST**

**Technical Support: 760-536-3640**

# GLASSWAREHOUSE

Register Your Warranty Today!

To activate your limited lifetime warranty, please visit:  
<http://www.glasswarehouse.us/contact/>



We will require this information within 30 days of purchase to complete the activation of your warranty.